

REVISIONS			
REV.	DESCRIPTION	DATE	APPROVED
A	INITIAL RELEASE	4/5/12	AMK
B	Material Change	3/14/16	AMK

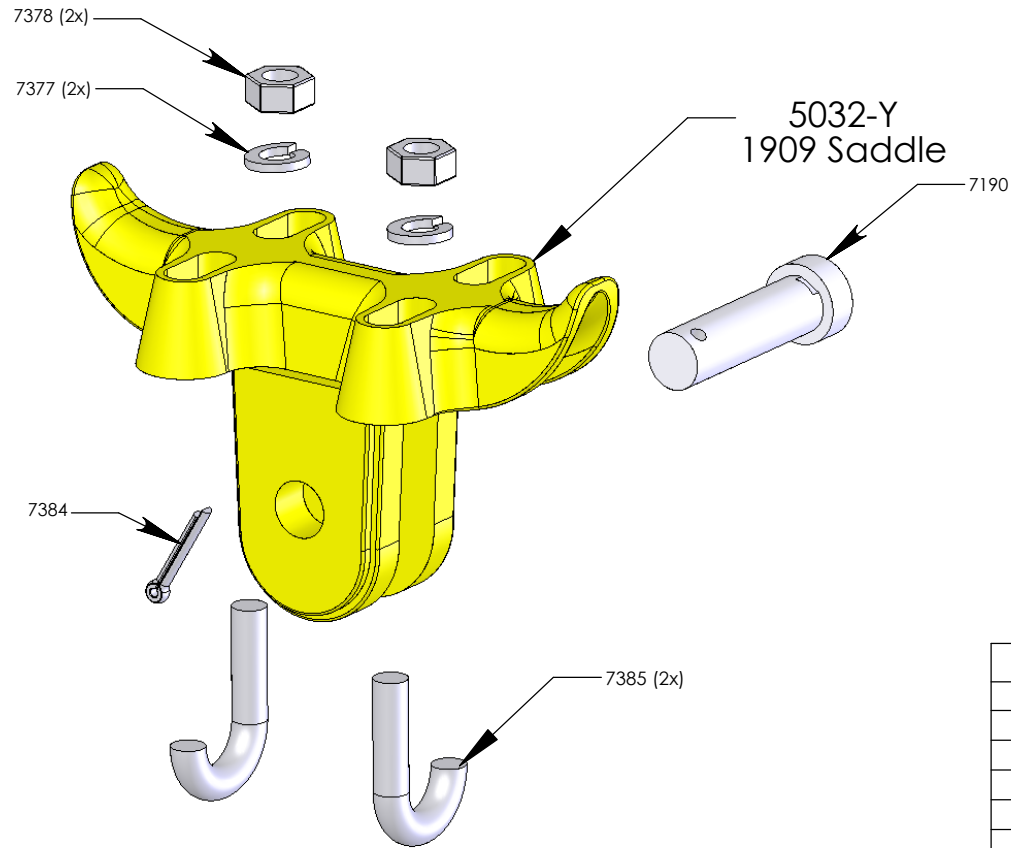

ITEM NO.	PART DESCRIPTION	QTY
<b>5032-Y</b>	<b>1909 Span Wire Clamp, Yellow, Al Alloy 535.0,</b>	1
7385	3/8"-16 x 5/8" J-Bolt, Galv	2
7378	3/8"-16 Hex Nut	2
7377	3/8" Washer, Lock	
7190	5/8" Clevis Pin (Rivet), Zinc	1
7384	Cotter Pin for 5/8" Clevis	1

	NAME	DATE	UNLESS OTHERWISE SPECIFIED:		
DRAWN	H. E. RB	4/7/09	DIMENSIONS ARE IN INCHES TOLERANCES: ANGULAR: MACH ± 1/32" TWO PLACE DECIMAL ± .03" THREE PLACE DECIMAL ± .010"		
CHECKED			INTERPRET GEOMETRIC TOLERANCING PER:		
ENG APPR.	AMK	4/7/09	MATERIAL VARIOUS		
MFG APPR.			FINISH VARIOUS		
<b>PROPRIETARY AND CONFIDENTIAL</b> THE INFORMATION CONTAINED IN THIS DRAWING IS THE SOLE PROPERTY OF COST CAST, INC. ANY REPRODUCTION IN PART OR AS A WHOLE WITHOUT THE WRITTEN PERMISSION OF COST CAST, INC. IS PROHIBITED.			<b>COST CAST, INC</b>  TITLE: <b>1909-NZ-JY</b> Span Wire Clamp Assembly Yellow, J-Hook Attachment		
			SCALE: 1:5	WEIGHT:	SHEET 1 OF 1

5

↑

4

3

2

1